

General Description

The AS1130 is a single-chip, CMOS solution for Power over Ethernet (PoE). Applications include Voice over IP (VoIP) Phones, Wireless LAN Access Point, Security and Web Cameras, Analog Telephone Adapters (ATA) and Point of Sales Terminals.

By using high-volume standard CMOS technology, Akros enables its customers to bring to market higher performance PoE devices with low cost and a small footprint.

The AS1130 integrates surge protection, a PD controller, and a DC-DC converter. This high level of integration provides faster response to surge events and limits stray surge current from passing through sensitive circuits, such as the Ethernet PHY device. The device is designed to provide a safe low impedance discharge paths directly back to the earth ground, resulting in superior reliability and circuit protection.

The AS1130 supports power requirements of the emerging IEEE® 802.3at specification. The device provides an extended classification scheme that allows for higher classes, as power requirements cross above the limits of IEEE® Std. 802.3af-2003

Features

The AS1130 is a fully integrated PD and architected at a system level to provide the following features:

- Fully supports IEEE® Std. 802.3af-2003 and the pre-standard IEEE® Std. 802.3at power requirements
- Integrated cable discharge protection meets IEC 61000-4-2/3/4/5/6 requirements for electric discharge
- Meets IEC 60950 overvoltage protection
- Integrated DC-DC converter provides exceptional EMI performance
- Programmable DC current limit up to 800 mA
- Supports "two finger" classification for pre-standard IEEE® Std. 802.3at-2006 higher power PD applications
- Provides seamless support for local power
- Over temperature protection
- 5x5 mm QFN Package, RoHS compliant

Typical Applications

- Voice over IP (VoIP) phones
- Wireless LAN Access Points (WAP)
- Pan, Tilt and Zoom security and Web Cameras
- Analog Telephone Adapters (ATA)
- Point of Sale (PoS) Terminal

Example Application Diagram

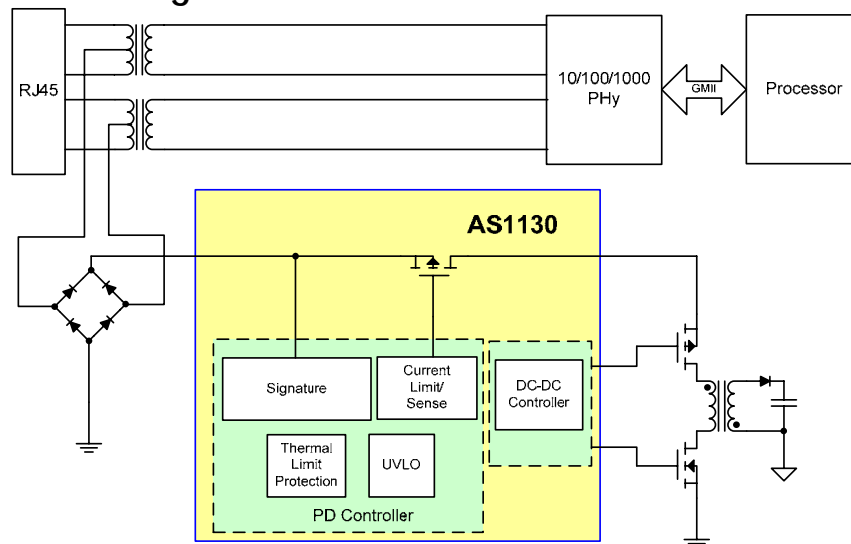

Figure 1, Typical Application Diagram for Gigabit Ethernet based PD (Flyback converter)

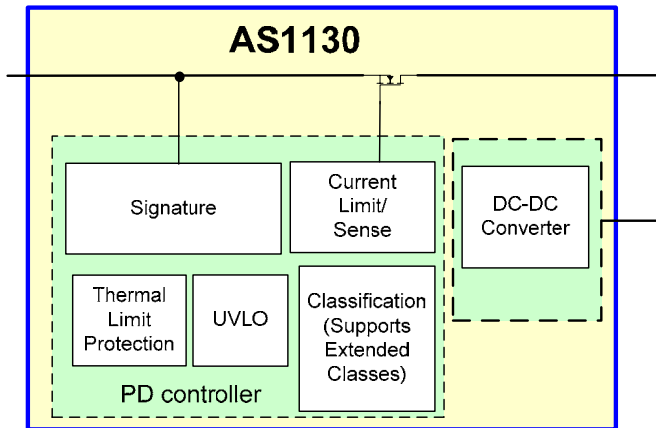

Figure 1: Top-Level Block Diagram of the AS1130

Description

The AS1130 is a fully integrated PD that provides functions required for Power over Ethernet (PoE) applications and is scalable to support higher power applications over 2 pairs of CAT5e/6 cables. The device's optimized architecture reduces external component cost, in a small footprint package, while providing high performance.

PD Control

The AS1130 PD control interface is designed to provide a fully compliant IEEE 802.3at and higher powered PD system, with programmable support for the standard PD control functions. The PD Control provides the following major functions:

- Signals that it is a PD
- Determines the mode of operation of the AS1130, based on the IEEE 802.3at standard.
- Determines the mode of operation of the AS1130, based on the extended classification for higher power option.
- Manages power and thermal protection overrides.

Modes of Operation

The AS1130 has four modes of operation:

1. Signature Detection - The PD signature is detected by the AS1130 to allow classification.
2. Classification - The PD signature is classified, to determine the power requirements of the PD.
3. Normal Operation - The PD is supplied the proper power by the AS1130.

4. Disable - PSE voltage is below normal and the power to the PD is off.

As the supply voltage from the PSE increases from initial 0V, the part transitions through the modes of operation in this sequence:

Disable → Signature Detection → Classification → Normal Operation

If no PSE is present, the AS1130 remains in the disable mode and does not affect the Ethernet link.

PD Control Power and Thermal Protections

The AS1130 provides the following features for PD Control Power and Thermal protection:

- Under Voltage Lockout (UVLO)—The UVLO circuitry detects conditions when the voltage is too low, and disconnects the power to protect the PD.
- Current Limit/Current Sense—senses the operating current via the sense resistor and regulates the gate voltage on the on-chip power MOSFET to minimize on-chip Power dissipation.
- Thermal Limit/Protection—the AS1130 provides thermal protection for the IC by monitoring die temperatures and reducing current, or disconnecting power as appropriate.

DC-DC Conversion

The integrated DC-DC converter operates from a switched input voltage and includes soft-start and current limiting. After the input power and enable signals are asserted, the DC-DC controller starts up. The converter provides control signals to external MOSFET switches and uses an external sense resistor to sense the transformer primary current.

As part of a full system level solution for EMI, Akros has focused significant effort in reducing switching noise in the integrated power converters through unique techniques of balancing the signaling of the FET drivers and reducing ground bounce by minimizing the dV/dt switching noise.

The DC-DC architecture is a current mode converter which can be configured with external component changes for either flyback, forward or buck topologies. Both non-isolated and isolated switching technologies are supported. The PWM switching signal is controlled for low radiated and conducted emissions.

For More Information

Contact us at marcom@akrossilicon.com, or **Akros Silicon**,
275 Turn Pike Drive, Folsom, CA95630